

# DR<sup>®</sup> SNOW THROWER

*Safety, Operation & Maintenance Instructions*

---

Model: 8157

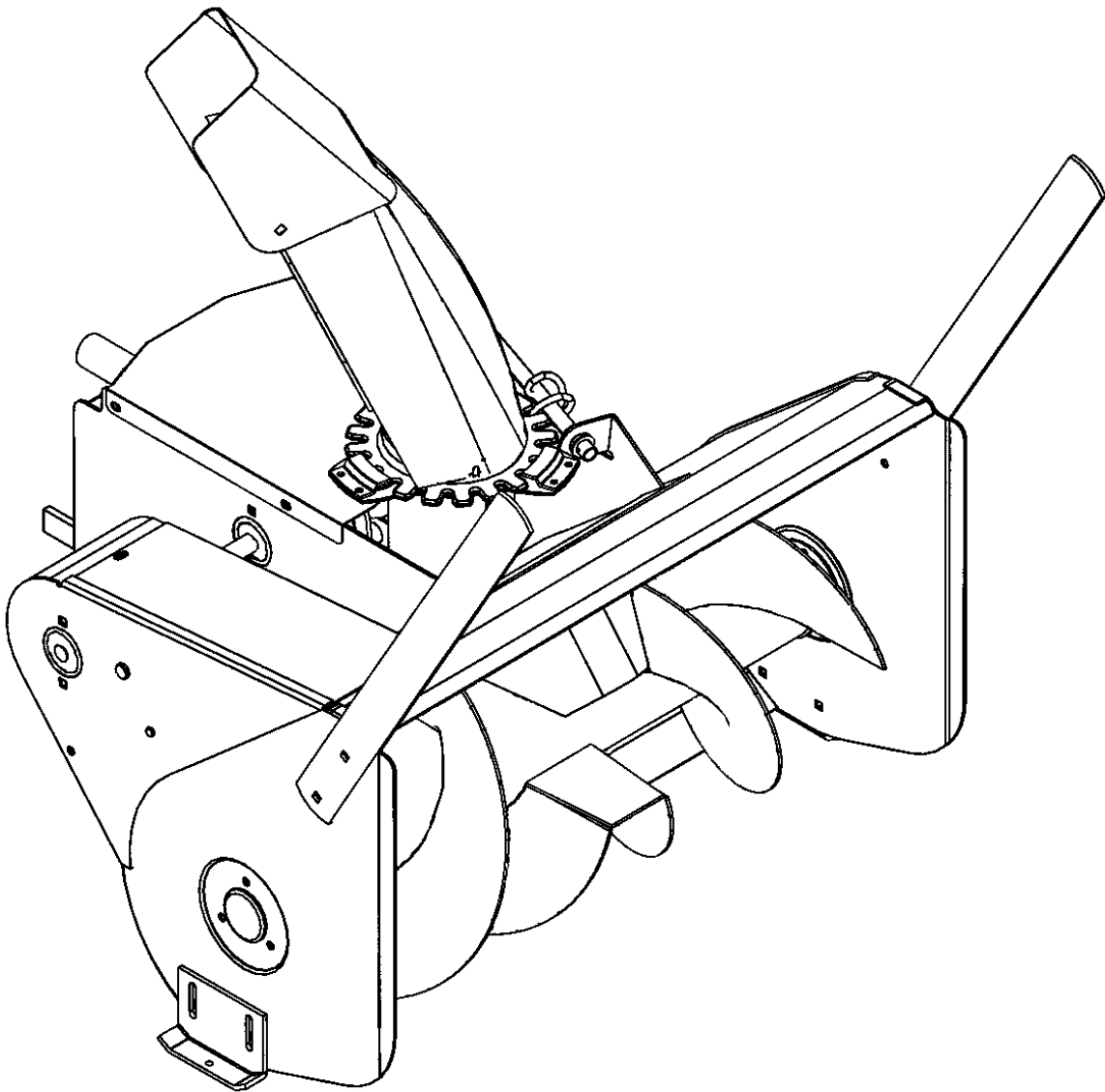

**30" Single Stage SNOW THROWER for use with DR<sup>®</sup> ALL-TERRAIN<sup>™</sup> MOWERS**  
**Models: A2080BMA, A2080BEA, A2105BEA, A2125TEA, A2150KEA, A2090TMA, A2090TEA,**  
**A2110BEA, A2130BEA & A2150KEA**

**SERIAL NO. 2015280 and up**

OM 0308  
10/02



# TABLE OF CONTENTS

---

INTRODUCTION – TO THE PURCHASER.....	4
SAFETY PRECAUTIONS.....	5
Before Operation .....	5
Notice.....	6
The DR® SNOW THROWER .....	6
Before Operation .....	6
Operating the DR® SNOW THROWER .....	7
Maintenance.....	8
Storage.....	8
DECALS.....	9
ASSEMBLY & INSTALLATION .....	10
Step 1: Preparation .....	10
Step 2: Chute Installation .....	11
Step 3: Installation.....	12
Step 4: Belt Installation .....	12
Step 5: Rotation Handle Installation.....	13
Step 6: Optional Drift Cutters Installation.....	14
Removing the DR® SNOW THROWER.....	14
OPERATION.....	15
Operating Controls .....	15
Adjustments.....	15
General Preparation.....	16
Increasing Traction & Stability .....	16
Engine Speed.....	16
Snow Removal.....	16
Snow Removal Methods.....	17
MAINTENANCE.....	18
Drive Chain Replacement.....	18
Drive Belt Replacement .....	18
Shear Bolt Replacement .....	19
Lubrication .....	19
Storage.....	19
SPECIFICATIONS .....	20
PARTS .....	21
Introduction.....	21
30" DR® SNOW THROWER - 8157.....	22
Chute with Deflector.....	24
Manual Chute Rotation System .....	25
Optional Drift Cutters - 8173.....	26
TORQUE SPECIFICATION TABLE.....	27

# INTRODUCTION

---

## To the Purchaser

This product is designed to give safe, dependable service if it is operated and maintained according to these instructions.

**Read and understand this manual before operation.**

This manual has been prepared to assist the owner/operators in the safe operation and suitable maintenance of the DR<sup>®</sup> SNOW THROWER. The information was applicable to products at the time of manufacture and does not include modifications made afterwards.

Read and understand this operator's manual before attempting to put a DR<sup>®</sup> SNOW THROWER into service. Familiarize yourself with the operating instructions and all the safety recommendations contained in this manual and those labeled on the DR<sup>®</sup> SNOW THROWER and on the DR<sup>®</sup> ALL-TERRAIN<sup>™</sup> MOWER. Follow the safety recommendations and make sure that those with whom you work follow them.

## Illustrations

The illustrations may not necessarily reproduce the full detail and the exact shape of the parts or depict the actual models, and are intended for reference only.

## Direction Reference

All references to right and left, forward or backward, are from the operator steering the DR<sup>®</sup> ALL-TERRAIN<sup>™</sup> MOWER.

*To assist our Customer Service Department in handling your needs, please record hereafter the model number and serial number of your DR<sup>®</sup> SNOW THROWER and DR<sup>®</sup> ALL-TERRAIN<sup>™</sup> MOWER. It is also advisable to supply them to your insurance company. It will be helpful in the event that your DR<sup>®</sup> SNOW THROWER or DR<sup>®</sup> ALL-TERRAIN<sup>™</sup> MOWER is lost or stolen.*

---

**DR<sup>®</sup> ALL-TERRAIN<sup>™</sup> MOWER**

**DR<sup>®</sup> SNOW THROWER**

MODEL: \_\_\_\_\_

SERIAL NUMBER: \_\_\_\_\_

DATE OF PURCHASE: \_\_\_\_\_

DEALER NAME: \_\_\_\_\_

*(If applicable)*

# SAFETY PRECAUTIONS

---



## SAFETY FIRST

This symbol, the industry's "Safety Alert Symbol" is used throughout this manual and on the machine's labels to warn of the possibility of personal injury. Read these instructions carefully. It is essential that you read the instructions and safety regulations before you attempt to assemble or use this unit.



**DANGER:** Indicates an immediately hazardous situation which, if not avoided, will result in death or serious injury.



**WARNING:** Indicates a potentially hazardous situation which, if not avoided, could result in death or serious injury.



**CAUTION:** Indicates a potentially hazardous situation which, if not avoided, may result in minor or moderate injury.

**IMPORTANT:** Indicates that equipment or property damage could result if instructions are not followed.

**NOTE:** Gives helpful information.

This product is designed to give safe, dependable service if it is operated and maintained according to these instructions. **Read and understand this manual before operation.** It is the Owner's responsibility to be certain anyone operating this product reads this manual, and all other applicable manuals, to become familiar with this equipment and all safety precautions. Failure to do so could result in serious personal injury or equipment damage.

## **Before Operation**

### **Children**

Tragic accidents can occur if the operator is not alert to the presence of children. Children are generally attracted to machines and the work being done. Never assume children will remain where you last saw them.

1. Keep children out of the operating area and under the watchful eye of another responsible adult.
2. Be alert and turn machine off if children enter the work area.
3. Before and when backing up the machine, look behind for small children.
4. Never allow children to play with the machine or attachment even when they are turned off.
5. Never allow children to operate the machine even under adult supervision.
6. Use extra care when approaching blind corners, shrubs, trees, or other obstructions that might hide children from sight.

# SAFETY PRECAUTIONS

---

## **Notice...**

A safe operator is the best assurance against accidents. All operators, no matter how experienced they may be, should read this operator's manual and all other related manuals before attempting to operate a DR<sup>®</sup> SNOW THROWER. Please read the following section and pay particular attention to all safety recommendations contained in this manual and those labeled on the DR<sup>®</sup> SNOW THROWER and on the DR<sup>®</sup> ALL-TERRAIN<sup>™</sup> MOWER.

### **Before Operating the DR<sup>®</sup> SNOW THROWER**

1. Read and understand this operator's manual and the DR<sup>®</sup> ALL-TERRAIN<sup>™</sup> MOWER operator's manual. Know how to operate all controls and how to stop the unit and disengage the controls quickly.
2. Never wear loose, torn, or bulky clothing around the DR<sup>®</sup> ALL-TERRAIN<sup>™</sup> MOWER and the DR<sup>®</sup> SNOW THROWER. It may catch on moving parts or controls, leading to the risk of accident.
3. Before using the equipment, thoroughly inspect the area where the equipment is to be used and remove all objects that may damage the equipment.
4. Disengage the clutch and shift into neutral before starting the engine.
5. Do not operate equipment in wintertime without wearing adequate winter garments.
6. Never attempt to make any adjustments while the engine is running. Read this manual carefully to acquaint yourself with the equipment as well as the DR<sup>®</sup> ALL-TERRAIN<sup>™</sup> MOWER Operator's Manual. Working with unfamiliar equipment can lead to accidents. Be thoroughly familiar with the controls and proper use of the equipment.
7. Replace all missing, illegible, or damaged safety and warning decals. See list of decals in the Operator's Manual.
8. Do not modify or alter this equipment or any of its components, or any equipment function. Doing so will void your warranty.
9. Keep safety decals clean of dirt and grime.
10. Keep all shields in place and properly tighten all mounting hardware.

# SAFETY PRECAUTIONS

---

## Operating the DR<sup>®</sup> SNOW THROWER

**Never operate the DR<sup>®</sup> SNOW THROWER without good visibility and lighting.**

1. Do not make mechanical adjustments while the unit is in motion, the DR<sup>®</sup> SNOW THROWER is raised, or the engine is running.
2. Do not put hands or feet near rotating parts. Keep clear of discharge opening at all times. Do not use hands or feet to unclog spout.
3. Never allow anyone to sit or stand on the equipment at any time.
4. Before leaving the DR<sup>®</sup> ALL-TERRAIN<sup>™</sup> MOWER unattended, take all necessary precautions. Park the DR<sup>®</sup> ALL-TERRAIN<sup>™</sup> MOWER on level ground, place the transmission in neutral, set the parking brake, disengage the driving system, place all levers including auxiliary control levers in neutral, shut off the engine and remove the ignition key.
5. Exercise extreme caution when operating on or crossing gravel driveways, walks, or roads. Stay alert for hidden hazards or traffic.
6. Do not run the engine indoors except when starting engine and transporting attachment in or out of building. Carbon monoxide gas is colorless, odorless and deadly.
7. Do not attempt to operate on steep slopes or near embankments.
8. Use extra caution when backing up.
9. Prolonged exposure to loud noise can cause impairment or loss of hearing. Wear a suitable hearing protection such as earmuffs or earplugs to protect your valuable hearing.
10. Always wear eye protection during operation (safety goggles, face shield, etc.).
11. Never allow anyone to operate the equipment until they read the manual completely and are thoroughly familiar with basic DR<sup>®</sup> ALL-TERRAIN<sup>™</sup> MOWER and equipment operation.
12. Always make sure all equipment components are properly installed and securely fastened BEFORE operating.
13. Adjust collector-housing height to clear gravel or crushed rock surface.
14. If the DR<sup>®</sup> SNOW THROWER starts to vibrate abnormally, stop the engine immediately, disconnect the spark plug wire and check for cause. Excessive vibration is generally a sign of trouble.
15. Never operate the DR<sup>®</sup> SNOW THROWER without guards and other safety protective devices in place.
16. Do not direct the discharge chute at bystanders or animals. Ejected objects may cause injury.

**Read the separate DR<sup>®</sup> ALL-TERRAIN<sup>™</sup> MOWER Operator's Manual carefully before using the machine. Lack of operating knowledge can lead to accidents.**

# SAFETY PRECAUTIONS

---

## Maintenance

***ALWAYS USE GENUINE PARTS WHEN REPLACEMENT PARTS ARE REQUIRED***

**⚠ WARNING:** Always disconnect the spark plug wire before servicing your machine.

1. Park the DR<sup>®</sup> *ALL-TERRAIN*<sup>™</sup> MOWER on level ground, set the parking brake, disengage the driving system, place all levers including auxiliary control levers in neutral, shut off the engine and remove the spark plug wire BEFORE making any adjustments.
2. Make sure all shields and guards are securely in place following all service, cleaning, or repair work.
3. To avoid injury, do not adjust, unclog or service the equipment with the DR<sup>®</sup> *ALL-TERRAIN*<sup>™</sup> MOWER engine running. Make sure rotating components have completely stopped and the spark plug wire is disconnected BEFORE making any adjustments.
4. Keep the DR<sup>®</sup> *ALL-TERRAIN*<sup>™</sup> MOWER/ equipment clean. Build-up of debris can lead to malfunction or serious personal injury.
5. Always wear eye protection when cleaning or servicing the equipment.
6. Do not modify or alter this equipment or any of its components or operating functions.
7. Change the oil to an appropriate grade for winter use. Consult your engine manufacturer's owner's manual.

## Storage

Before storing the equipment, certain precautions should be taken to protect it from deterioration:

**⚠ WARNING:** Always disconnect the spark plug wire before servicing your machine.

1. Clean the equipment thoroughly.
2. Make all the necessary repairs.
3. Replace all Safety Decals that are damaged, lost, or otherwise become illegible. If a part to be replaced has a decal on it, obtain a new safety decal and install it in the same place as on the removed part.
4. Repaint all parts from which paint has worn or peeled.
5. When the DR<sup>®</sup> SNOW THROWER is dry, lubricate all moving parts. Apply Fluid Film<sup>®</sup> or comparable lubricant liberally to all surfaces to protect against rust.
6. Store in a dry place.



# DECALS

## Replace Immediately if Damaged

(See Parts section for decal location)



657762

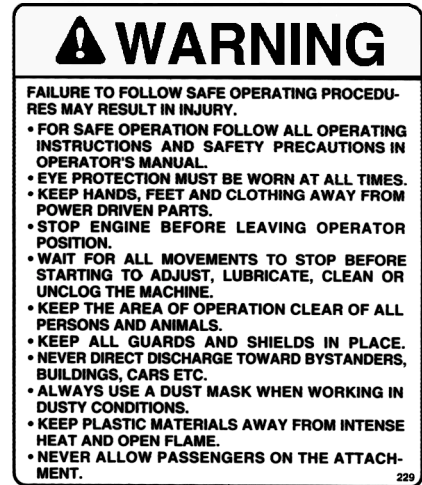

660988

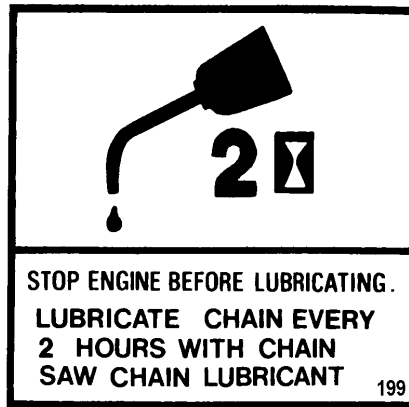

660263



660265



657761

# ASSEMBLY & INSTALLATION

## Step 1: Preparation (Figure 1)

After opening the crate and removing all the cardboard, remove the box containing the chute and the instructions (item 2).

1. Remove the two screws (item 4) that retain the housing (item 1) on the pallet (item 3).
2. Verify that you have all components on the following list:

If anything is missing, please call one of our Customer Service Representatives TOLL-FREE 1(800)DR-OWNER(376-9637).

Crate	
Qty	Item
1	DR <sup>®</sup> SNOW THROWER assembly
1	Chute assembly
1	Rotation handle
1	Worm shaft
1	Bag
Bag	
1	Handle support
3	Retaining plates
1	U bolt 1/4" NC x 1 1/8" x 2", PTD
2	Plastic bushings
6	Hex. bolts 1/4" NC x 1/2", PTD
6	Flange nuts 1/4" NC, PTD
1	Flatwasher 41/64" I.D.
1	Hairpin 2mm x 41mm, PTD
1	Cotter pin 1/8" x 1 3/4", PTD
1	Operator's Manual
1	Packing list
1	Spare shear bolt

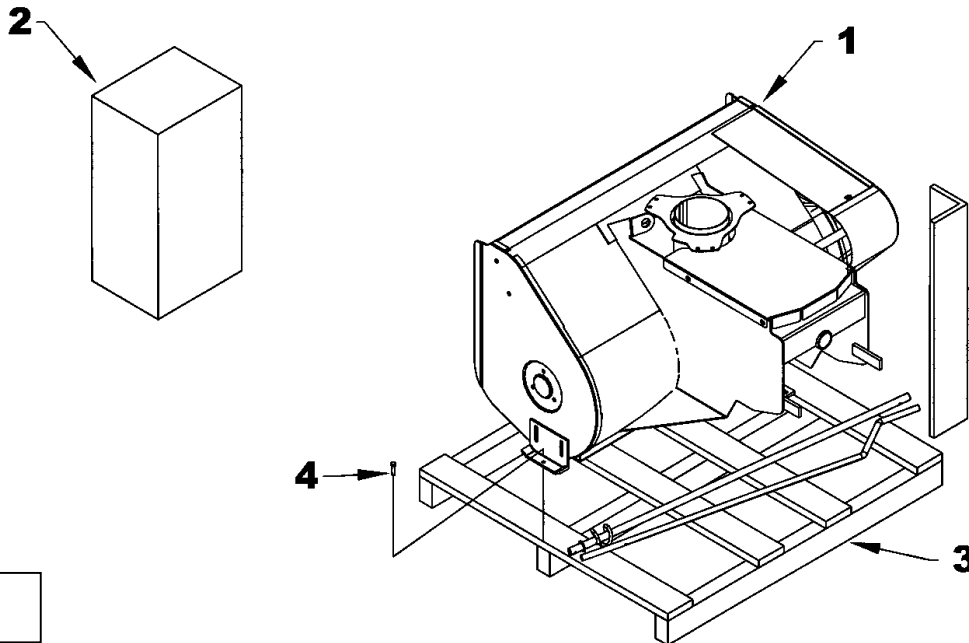

**Figure 1**

# ASSEMBLY & INSTALLATION

---

## **Step 2: Chute Installation (Figure 2)**

For assembly, place the DR<sup>®</sup> SNOW THROWER on a flat and level surface.

1. Place the chute (item 1) on the discharge hole (item 2) around the DR<sup>®</sup> SNOW THROWER.
2. Install the three retaining plates (item 3) using the six 1/4" x 1/2" bolts and flange nuts (items 4-5), tighten securely. Verify that the chute turns freely on the collar.

**Figure 2**

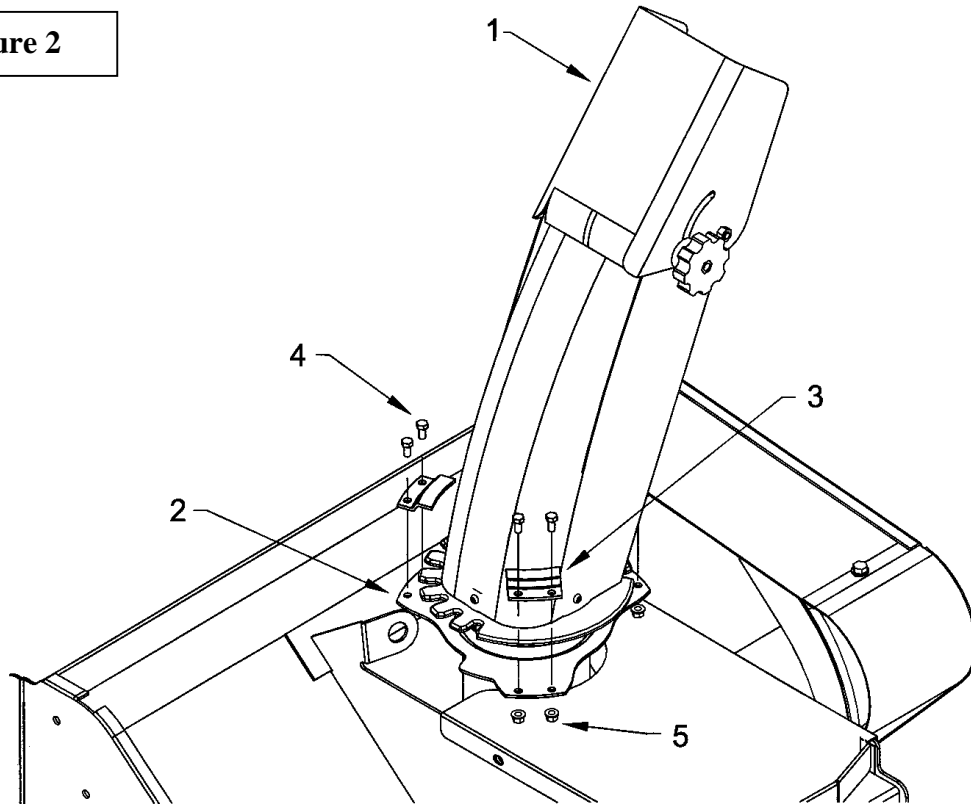

# ASSEMBLY & INSTALLATION

**⚠ WARNING:** Before installing the DR<sup>®</sup> SNOW THROWER, always bring the DR<sup>®</sup> ALL-TERRAIN™ MOWER to a complete stop, shut off the engine and remove the spark plug wire.

## **Step 3: Installation (Figure 3)**

1. Remove the mowing deck from the DR<sup>®</sup> ALL-TERRAIN™ MOWER.
2. Apply grease on the shaft (item 6).
3. Remove bolts (item 5) from belt cover.
4. Remove the belt cover (item 4).
5. Align the DR<sup>®</sup> ALL-TERRAIN™ MOWER and DR<sup>®</sup> SNOW THROWER. Carefully, insert the shaft (item 6) of the ALL-TERRAIN™ MOWER into the female attachment on the SNOW THROWER.
6. Reinstall the collar and pin used with the mower to secure the SNOW THROWER.

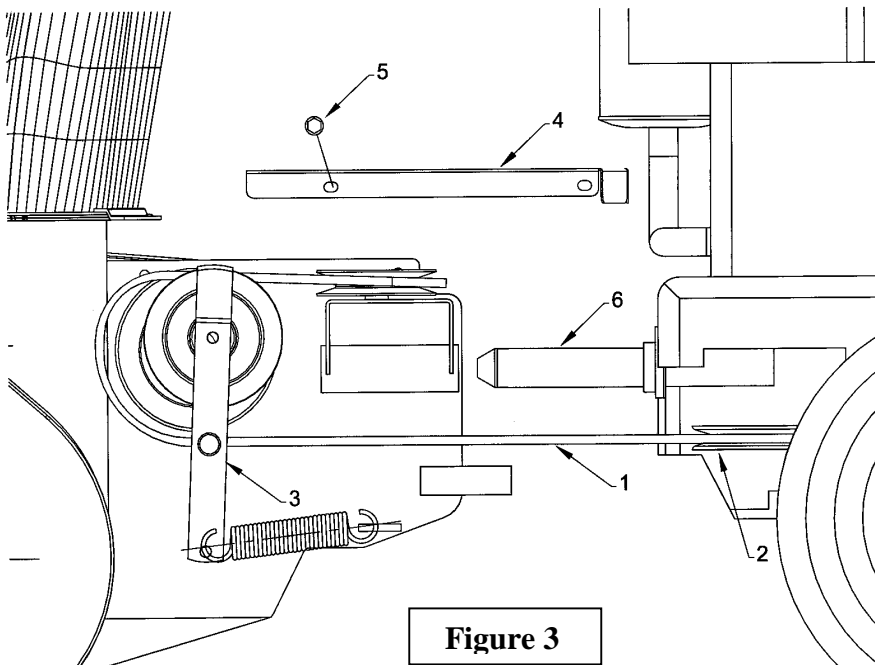

**Figure 3**

## **Step 4: Belt Installation (Figures 3 & 4)**

1. Carefully install the drive belt (item 1) around the drive pulley (item 2) under the DR<sup>®</sup> ALL-TERRAIN™ MOWER.
2. Pull the tensioner (item 3) to reinstall the belt on the idler. Make sure that the V-belt is not twisted and fits correctly in the V-groove on the pulley.
3. Make sure to position the belt above the belt guide, as shown in figure 4.
4. Reinstall the belt cover (item 4) and bolts.

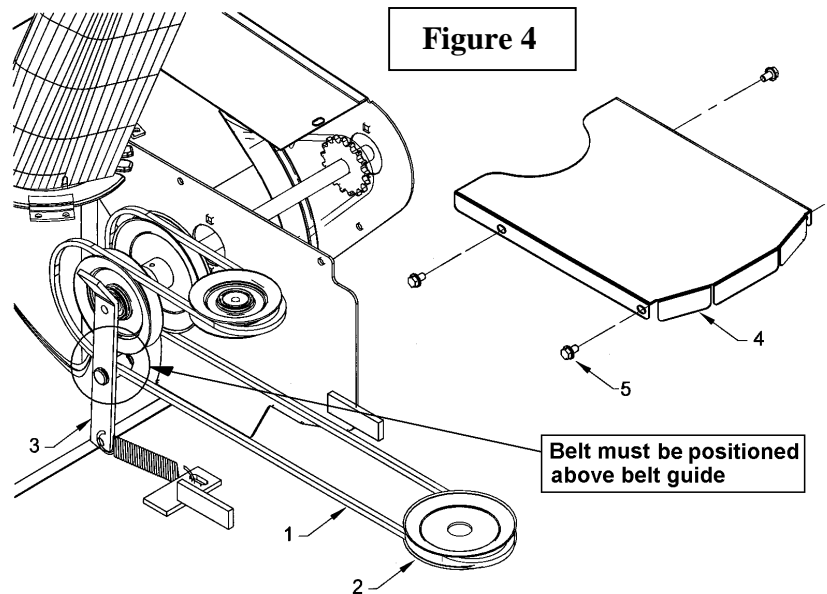

**Figure 4**

**Belt must be positioned above belt guide**

# ASSEMBLY & INSTALLATION

## Step 5: Rotation Handle Installation (Figure 5)

1. On the left side handlebar of the DR<sup>®</sup> ALL-TERRAIN™ MOWER, install the rotation handle support (item 1) at approximately 28" from the ground, using the U-bolt (item 2), plate and nuts.
2. Insert the plastic bushing (item 3, flange facing the operator) on the housing by pushing forward until it snaps.
3. Insert the worm shaft (item 4) in the plastic bushing.
4. Place the flat washer (item 5) and lock the shaft in place with the cotter pin (item 6).
5. Insert the plastic bushing (item 3, flange facing the operator) into the rotation handle support (item 1).
6. Insert the rotation handle (item 7) through the support then in the worm shaft (item 4). Secure with the hairpin (item 8).
7. Operate the handle and check for proper operation of the chute.

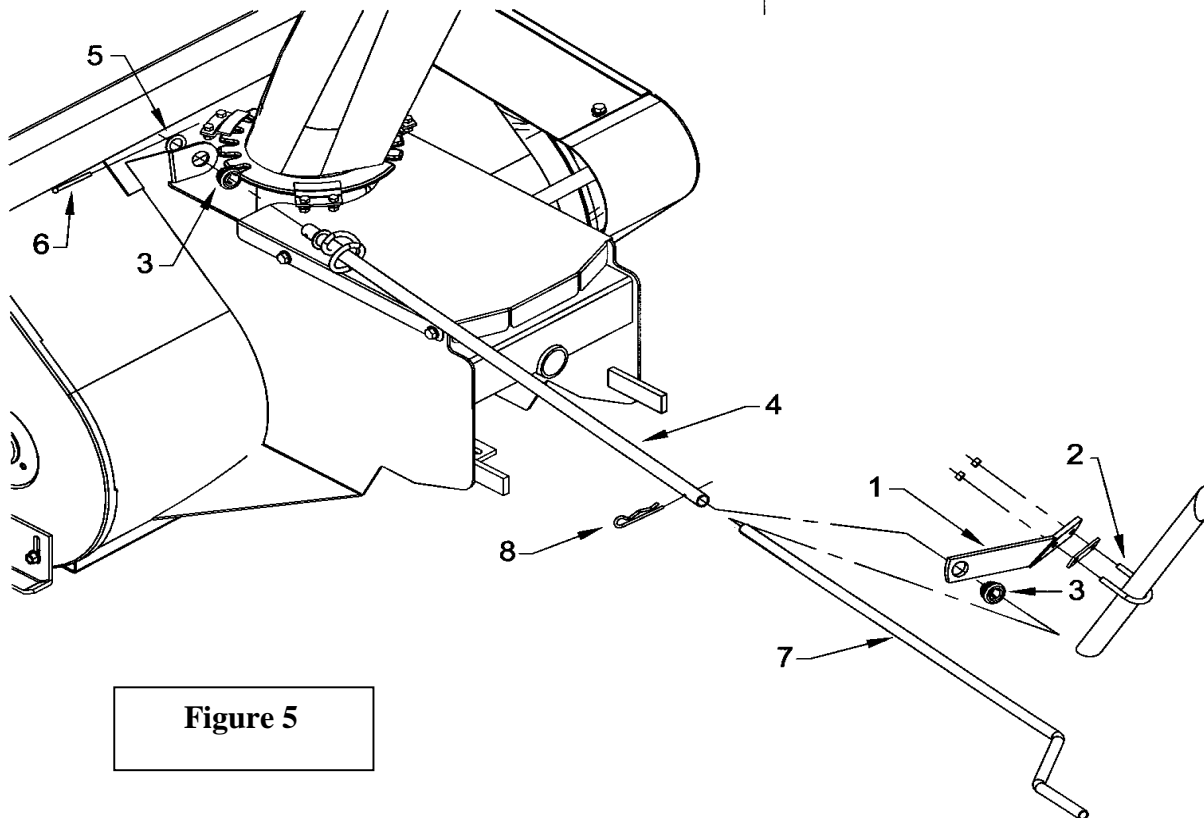

Figure 5

**⚠ WARNING:** Make sure the chute blocks in both directions to prevent the snow from being projected in the operator's area (Figure 6).

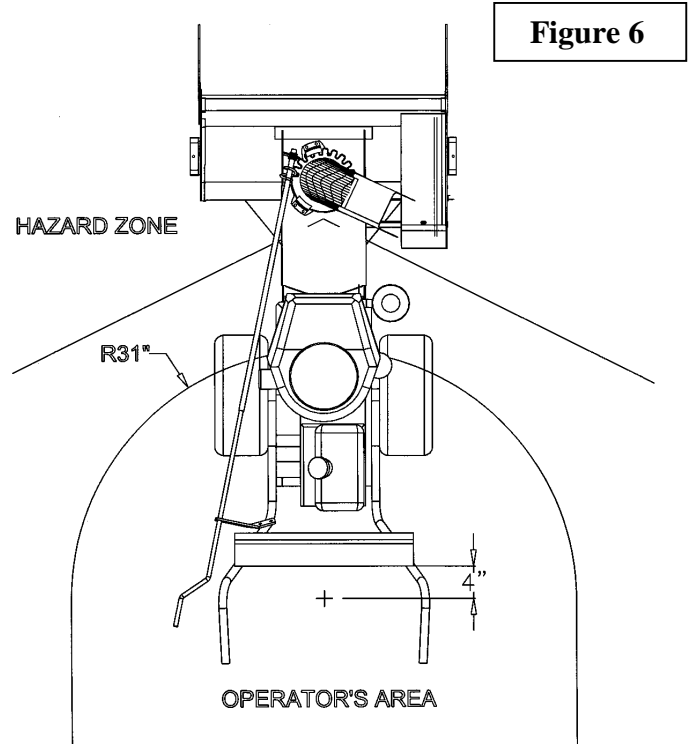

Figure 6

# ASSEMBLY & INSTALLATION

## Step 6: Optional Drift Cutters - 8173 Installation (Figure 7)

1. From the exterior of the housing, align the two square holes on the drift cutter (item 1) with the two round holes on the housing.
2. From the outside, insert the 5/16" x 5/8" carriage bolts (item 2).
3. Secure with two flange nuts (item 3).
4. Repeat on the other side.

## Removing the DR® Snow Thrower

1. Select a level surface, turn engine off and remove ignition key
2. Refer to Figure 5, Page 13. Remove hairpin (item 8) and rotation handle (item 7).
3. Refer to Figure 4, Page 12. Remove the belt cover (item 4).
4. Refer to Figure 3, Page 12. Pull the tensioner (item 3) to remove the drive belt (item 1).
5. Refer to Figure 3, Page 12. Unlock the pin (item 6) and carefully remove the DR® ALL-TERRAIN™ MOWER from the DR® SNOW THROWER.

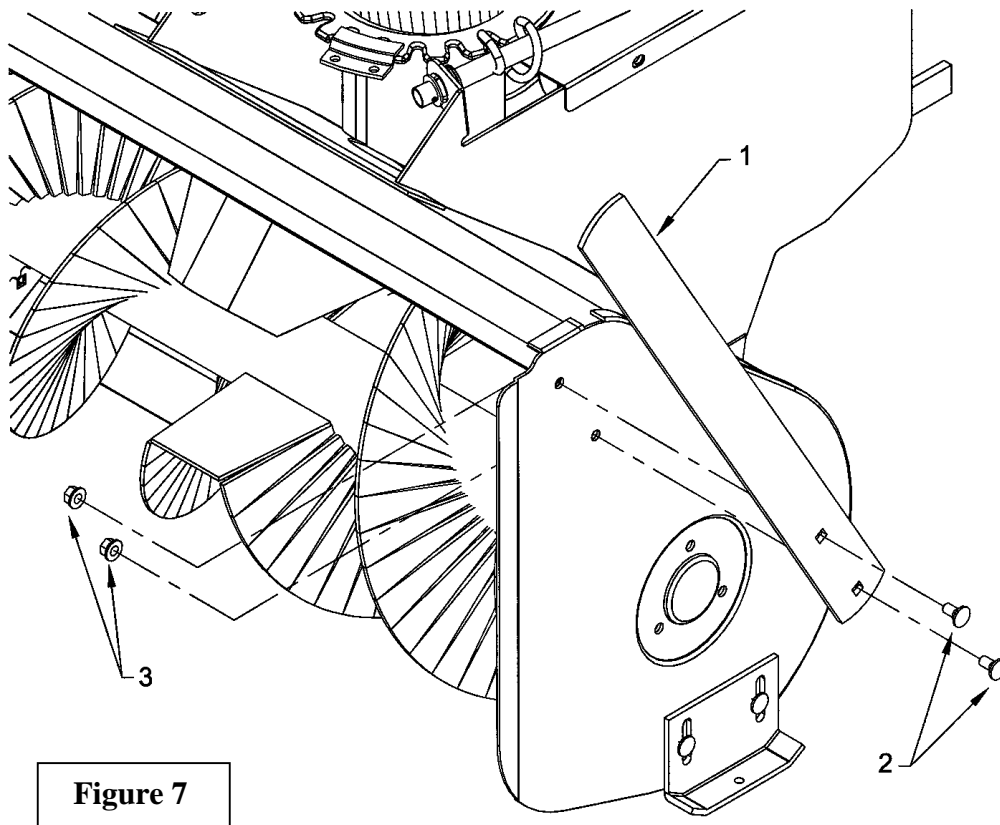

Figure 7

# OPERATION

## Operating Controls

The DR<sup>®</sup> SNOW THROWER is driven from the DR<sup>®</sup> ALL-TERRAIN<sup>™</sup> MOWER drive pulley.

### **⚠ WARNING:**

1. Do not allow bystanders near working area.
2. Do not allow anyone to ride on the DR<sup>®</sup> SNOW THROWER.
3. Before cleaning, adjusting or repairing the DR<sup>®</sup> SNOW THROWER: bring the DR<sup>®</sup> ALL-TERRAIN<sup>™</sup> MOWER to a complete stop, wait for all movement to stop, apply the parking brake, shut off the engine and remove the spark plug wire.
4. Never put any part of your body under the DR<sup>®</sup> SNOW THROWER while making adjustments.

## Chute Rotation

Adjust the chute direction with the rotation handle.

**⚠ WARNING:** Always keep the DR<sup>®</sup> SNOW THROWER discharge away from people, animals and objects which could be struck by debris.

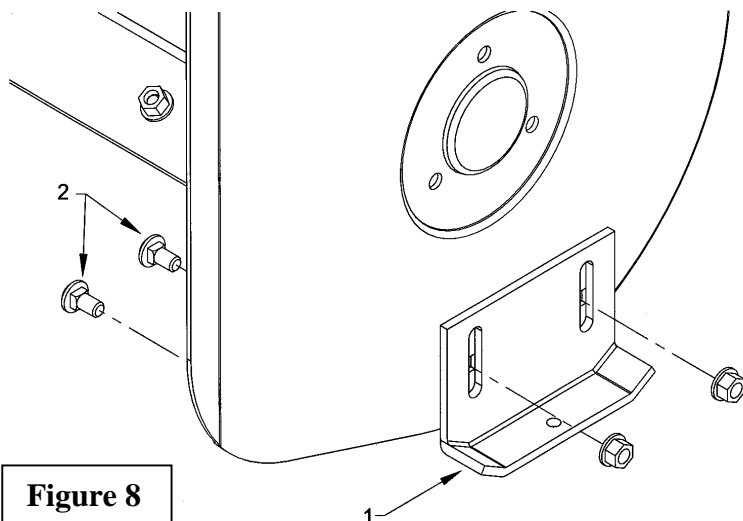

## Adjustments

### Deflector Adjustment

Adjust the deflector angle according to the distance the snow must be thrown. To adjust, loosen the knob, adjust to the desired angle then tighten knob securely.

### Skid Shoe Adjustment (Figures 8 & 9)

Adjust skid shoes in order to allow the required clearance (H) between the cutting edge and the surface, by loosening the 5/16" x 5/8" carriage bolts (item 2).

On level paved surface or asphalt roadway: leave 1/16" to 1/8" clearance (H).

On uneven or gravel surface, depending on gravel size: leave 1/2" to 5/8" clearance (H).

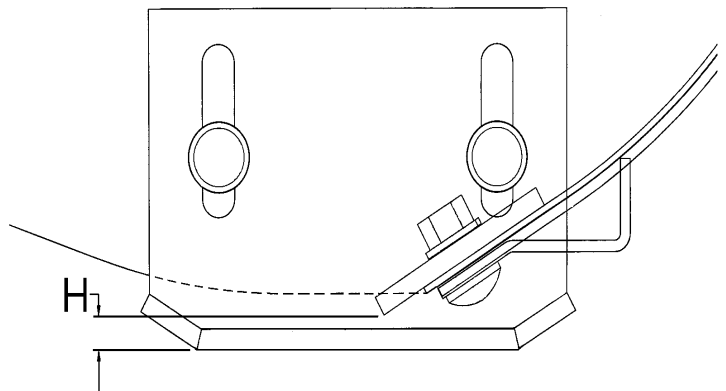

# OPERATION

---

## General Preparation

1. Use a winter grade oil in your DR<sup>®</sup> *ALL-TERRAIN™* MOWER. See the engine manufacturer's owner's manual.
2. Make sure that the auger operates freely.
3. Adjust the skid shoes so that the DR<sup>®</sup> SNOW THROWER runs level.
4. Make sure that the DR<sup>®</sup> SNOW THROWER is clear of snow before engaging the drive belt.

### **WARNING:**

1. Read this Operator's Manual carefully. Be thoroughly familiar with the controls and proper use of the equipment. Know how to stop the unit and disengage the controls quickly.
2. Never allow children to operate equipment. Never allow adults to operate equipment without proper instruction.
3. Keep the area of operation clear of people, animals and debris.
4. Clothing worn by the operator should be fairly tight and belted. Loose clothing should not be permitted because of the danger of getting into moving parts.

### Increasing Traction and Stability

Use DR<sup>®</sup> Tire Chains for extra traction and stability. Call 1(800)DR-OWNER(376-9637) to order.

### Engine Speed

 **CAUTION:** Use only moderate engine speed when engaging the drive belt. Engaging the belt at high speed will shorten the clutch life.

For maximum power, operate the engine at, or near, full throttle.

## Snow Removal

Never use the DR<sup>®</sup> SNOW THROWER as a snowplow. Do not push the snow, let the SNOW THROWER work its way through deep drifts. For best results, raise the SNOW THROWER and remove a top layer of snow. A second pass will remove the remaining snow.

If ground speed is too fast, the DR<sup>®</sup> SNOW THROWER may become overloaded and may clog. Maintain a ground speed suited for the job to be done.

In heavy snow, take on only enough snow to work easily. Engage and disengage the clutch lever to reduce the ground speed to a level that will allow the engine to keep its full revolution.

**NOTE:** Use full RPM power when removing wet, sticky snow. Low RPM power will tend to clog the chute.

 **WARNING:** Do not use your hands to unclog the chute. Use a short stick or board. Never attempt to clear clogged chute while the DR<sup>®</sup> *ALL-TERRAIN™* MOWER engine is running. If the chute clogs, disengage the drive belt, wait for all movement to stop, apply the parking brake, shut off the engine and remove the spark plug wire before unclogging.

**NOTE:** Run the DR<sup>®</sup> SNOW THROWER a few minutes after blowing snow to prevent freeze up of auger.



# OPERATION

## Snow Removal Methods

When removing snow, do not use the DR<sup>®</sup> SNOW THROWER as a dozer blade to push snow. Let the DR<sup>®</sup> SNOW THROWER work its way through deep drifts. If the speed of your DR<sup>®</sup> ALL-TERRAIN<sup>™</sup> MOWER is too fast, the DR<sup>®</sup> SNOW THROWER may become overloaded and clog. For best results, raise the DR<sup>®</sup> SNOW THROWER and remove the top layers of snow, or take a half-width pass. A second pass with the DR<sup>®</sup> SNOW THROWER will remove the remaining snow.

**IMPORTANT:** Use full RPM power when removing wet, sticky snow. Low RPM power will tend to clog the chute.

**NOTE:** In heavy snow, engage and disengage the clutch lever to reduce the ground speed to a level that will allow the engine to keep its full revolution.

**⚠ WARNING!** To avoid serious personal injury, do not use hands or feet to unclog chute. Do not attempt to clear clogged chute of snow while DR<sup>®</sup> ALL-TERRAIN<sup>™</sup> MOWER engine is running. If the chute clogs, disengage the drive shaft, shut off the engine, remove the spark plug wire and wait for all movement to stop, and then clear the snow from the chute.

A definite pattern of operation is required to thoroughly clean an area of snow. These patterns will avoid throwing snow in unwanted places as well as eliminating a second removal of snow.

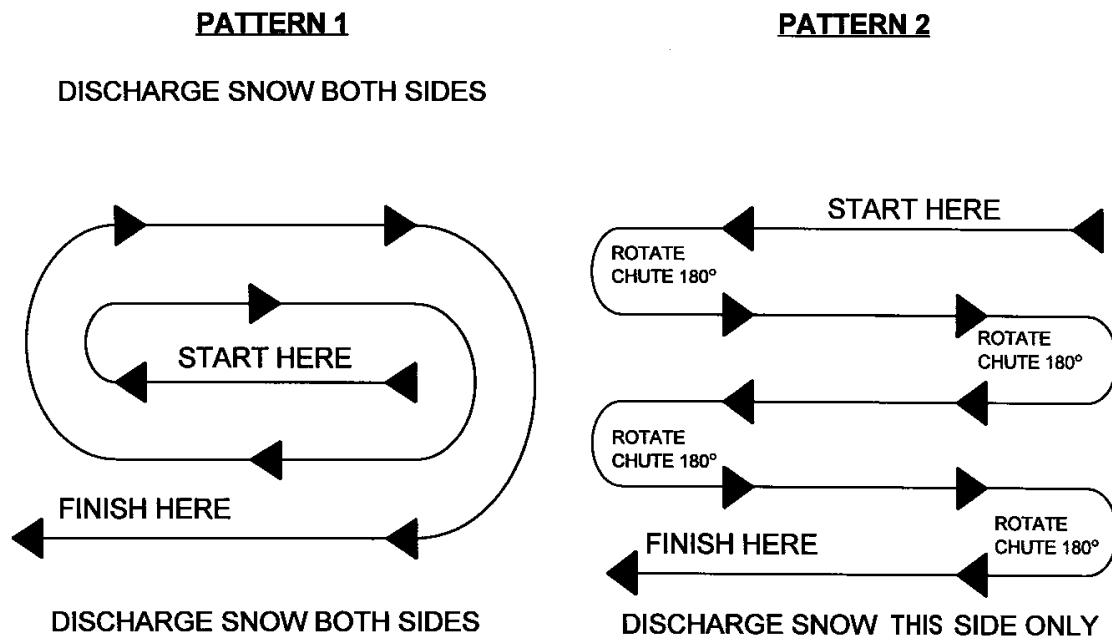

Where it is possible to throw the snow to the left and right (above), as on a long driveway, it is advantageous to start in the middle. Plow from one end to the other, throwing snow to both sides without changing the direction of the discharge chute.

If the snow can only be thrown to one side of the driveway or sidewalk (above), start on the opposite side. At the end of the first pass, rotate the discharge chute 180 degrees for the return pass. At the end of each succeeding pass, rotate the discharge guide 180 degrees to maintain direction of throw in the same area.

# MAINTENANCE

## ***ALWAYS USE GENUINE PARTS WHEN REPLACEMENT PARTS ARE REQUIRED***

**⚠ WARNING:** Never park the DR® ALL-TERRAIN™ MOWER with fuel in the fuel tank inside a building where an open flame or sparks are present. Allow the engine to cool down before storing in any enclosure.

**⚠ WARNING:** Provide adequate blocking before working under the DR® SNOW THROWER.

**⚠ WARNING:** Run the DR® SNOW THROWER a few minutes after throwing snow to prevent freeze up of auger.

## ***Drive Chain Replacement (Figure 10)***

Replace the chain when the distance between the sections of the chain (item 1) is reduced to 2" (see figure).

**⚠ WARNING:** Always disconnect the spark plug wire before servicing your machine.

1. Unbolt the chain cover (item 2) and remove it.
2. Remove the connecting link on the chain, and remove the chain.
3. Check the chain tensioner (item 5) for wear. Replace if necessary.
4. Install the new chain around the sprockets (items 3 & 4).
5. Pull the tensioner (item 5) and install the connecting link on the new chain.
6. Release the tensioner on the chain.
7. Lubricate the new chain with chain saw lubricant.
8. Reinstall the cover.

**Figure 10**

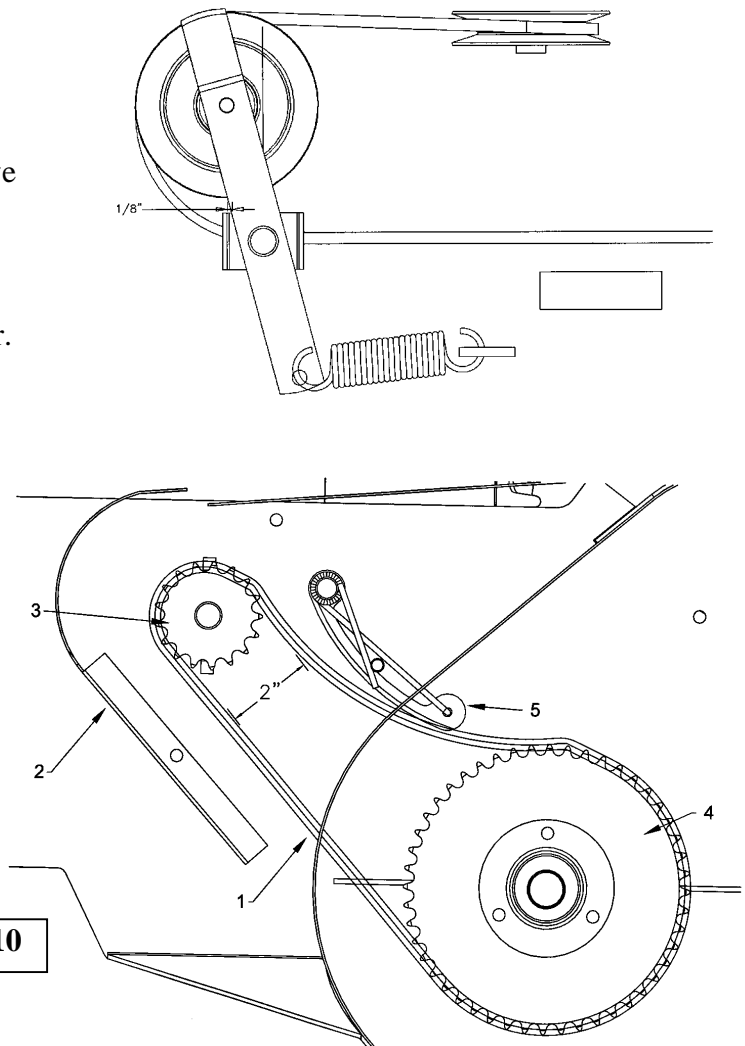

## ***Drive Belt Replacement (Figure 4, Page 12)***

When the belt tensioner is 1/8" close to its support (see figure below) due to belt elongation or after the equivalent of 60 hours of continuous operation, replace the drive belt.

**⚠ WARNING:** Always disconnect the spark plug wire before servicing your machine.

1. Remove the bolts (item 5) to remove the belt cover (item 4).
2. Pull the tensioner (item 3) and remove the belt (item 1) from the pulleys.
3. Install the new belt in the same pathway as the old one.
4. Re-engage the tensioner.
5. Reinstall the belt cover with the bolts.

# MAINTENANCE

## **Shear Bolt Replacement (Figure 11)**

If you strike a foreign object (wood, stone, etc.) there is a safety shear bolt on the driving system. This shear bolt will break, eliminating any driving force to the auger.

**⚠ WARNING:** Always disconnect the spark plug wire before servicing your machine.

1. To replace the shear bolt, stop the DR<sup>®</sup> ALL-TERRAIN™ MOWER and remove the spark plug wire.
2. Remove the bolts (item 1), and remove the belt cover (item 2).
3. Make sure that there is no debris remaining in the shaft hole.
4. Align the pulley hole with the shaft hole (item 3) and install the new shear bolt and nut (item 4). Tighten securely.
5. Reinstall cover and bolts.

## **Lubrication**

**⚠ WARNING:** Always disconnect the spark plug wire before servicing your machine.

Lubricate the drive chain with chain saw chain lubricant every 2 hours of operation **and also after each use.**

## **Storage**

Before storing the DR<sup>®</sup> SNOW THROWER, certain precautions should be taken to protect it from deterioration.

**⚠ WARNING:** Always disconnect the spark plug wire before servicing your machine.

1. Clean the DR<sup>®</sup> SNOW THROWER thoroughly.
2. Make all the necessary repairs.
3. Repaint all parts from which paint has worn or peeled.
4. Lubricate the DR<sup>®</sup> SNOW THROWER as instructed under *Lubrication*.
5. When the DR<sup>®</sup> SNOW THROWER is dry, lubricate all moving parts. Apply Fluid Film<sup>®</sup> or comparable lubricant liberally to all surfaces to protect against rust.
6. Store in a dry place.

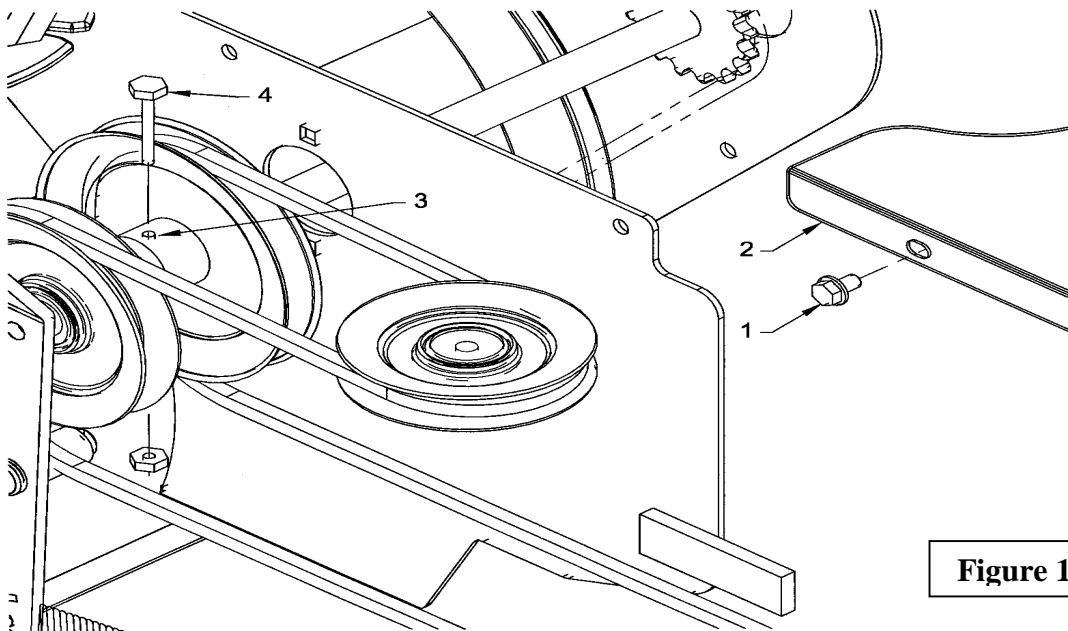

**Figure 11**

# SPECIFICATIONS

---

<b>Country Home Products Single Stage DR<sup>®</sup> SNOW THROWER</b>	
Overall width	30 1/2"
Overall height (without chute)	19 1/2"
Overall height (with chute)	37 1/2"
Overall length	29 1/8"
Cutting width	29 3/4"
Cutting height	18 1/4"
Frame thickness	16 Ga.
Side thickness	12 Ga.
Number of stages	1
Drive	'B" type belt and "B" type pulley
Drive pulley	5 3/4" O.D.
Idler belt adjustment	Automatic spring tensioner
Auger drive	# 40 chain and sprockets
Ratio	2,82:1
Auger RPM	1260 RPM
Idler chain adjustment	Automatic spring tensioner
Auger diameter	11 3/4"
Auger pitch	11 1/4"
Chute position	Center
Chute rotation	Manual
Adjustable deflector	Yes
Adjustable skid shoes	Yes
Replaceable cutting edge	Yes
Number of shear bolts on drive pulley	1
Optional Drift cutters	Optional
Hitch system	Fixed to Walk behind (cylindrical pin)
Weight with chute	126 lbs

# PARTS

---

## Introduction

All parts are illustrated in “exploded views” which show the individual parts in their normal relationship to each other. Reference numbers are used in the illustrations. These numbers correspond to those in the “Reference Number” (REF) column, and are followed by the description and quantity required.

O/L - “Obtain Locally” in the part number column indicates common hardware that is available at your local hardware supply.

All reference to right and left, forward or rearward, are from the operator steering the DR<sup>®</sup> *ALL-TERRAIN™* MOWER.

The manufacturer reserves the rights to change, modify, or eliminate from time to time, for technical or other reasons, certain or all data, specifications, or the product or products themselves, without any liability or obligation.

# PARTS

## 30" DR® SNOW THROWER - 8157

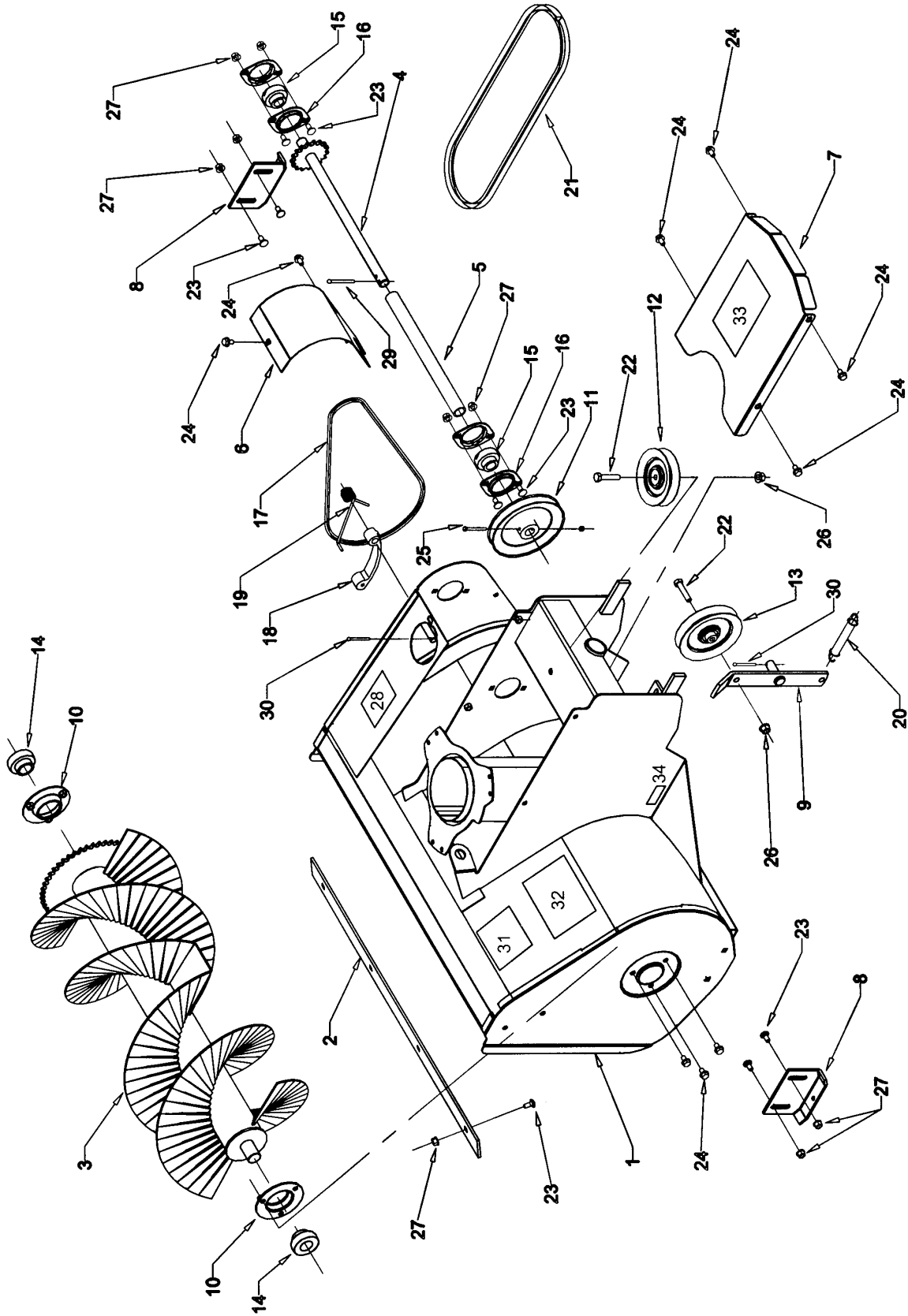

# PARTS

## 30" DR® SNOW THROWER - 8157

REF	DESCRIPTION	QTY	PART #
1	Frame	1	665939
2	Cutting edge	1	665727
3	Auger	1	665718
4	Driving shaft	1	665719
5	Protective shield	1	665742
6	Chain guard	1	665723
7	Belt cover	1	665725
8	Skid shoes	2	665677
9	Belt tensioner	1	665716
10	Bearing flange	2	665743
11	Pulley 5 3/4" dia.	1	4800002
12	Pulley 4 1/4" dia.	1	4800003
13	Pulley 4 15/16" dia.	1	4800004
14	Bearing dia. 1"	2	665494
15	Bearing dia. 3/4"	2	4300011
16	Flange	4	4300012
17	Chain #40	1	3300004
	Connecting link	1	659721
18	Chain tensioner	1	665960
19	Torsion spring	1	3800016
20	Tensioner spring	1	659087
21	V belt B78 5/8" x 81"	1	4800001
22	Hex. bolt 3/8" NC x 1 3/4" lg Gr.5	2	O/L
23	Carriage bolt 5/16" NC x 5/8" Gr.5	12	O/L
24	Serrated flange bolt 5/16" NC x 1/2" Gr.5	12	O/L
25	Shear bolt incl. nut	1	660894
26	Serrated flange nut 3/8" NC, PTD	2	O/L
27	Serrated flange nut 5/16"NC	12	O/L
28	Decal "Lubrication"	1	660263
29	Cotter pin 3/16" x 2" lg	1	O/L
30	Cotter pin 1/8" x 1 3/4" lg	2	O/L
31	Decal "Danger"	1	657762
32	Decal "SNOW THROWER"	1	2500325
33	Decal "Danger"	1	660265
34	Decal "Serial number"	1	2500322

O/L = Obtain Locally

# PARTS

## Chute with deflector

REF	DESCRIPTION	QTY	PART #
	Chute ass'y	1	665736
1	Chute base	1	665737
2	Deflector	1	665738
3	Retaining plate	3	657333
4	Plastic ring	1	665948
5	Knob	1	657309
6	Nylon washer dia. 7/16"	3	658468
7	Carriage bolt 5/16" NC x 5/8"	3	O/L
8	Machine screw 10-32 NC x 5/8"	3	2700008
9	Nylon insert locknut 5/16" NC	2	O/L
10	Nylon insert locknut 5mm x 0.8	3	1000020
11	Decal "Warning"	1	660988
12	Decal "Danger"	1	657761
13	Hex. bolt 1/4" NC x 1/2" NC Gr.5	6	O/L
14	Serrated flange nut 1/4" NC	6	O/L
15	Flatwasher 1/4"	3	O/L

O/L = Obtain Locally

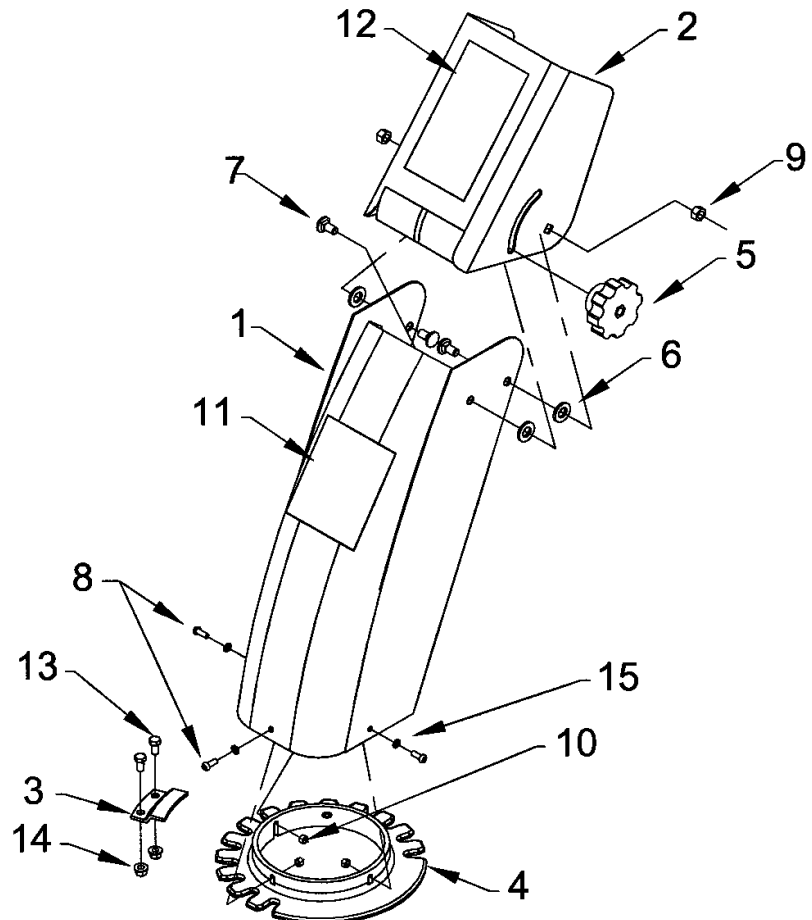



# PARTS

## Manual chute rotation system

REF	DESCRIPTION	QTY	PART #
1	Rotation handle	1	665733
2	Worm shaft	1	665734
3	Plastic bushing	2	665959
4	Handle support	1	665726
5	Flat washer 41/64"	1	O/L
6	Cotter pin 1/8" x 1 3/4"	1	O/L
7	Hairpin 1/16" x 1 5/8"	1	O/L
8	U bolt 1/4" NC x 1 1/8", including nuts and plate	1	0400020

O/L = Obtain Locally

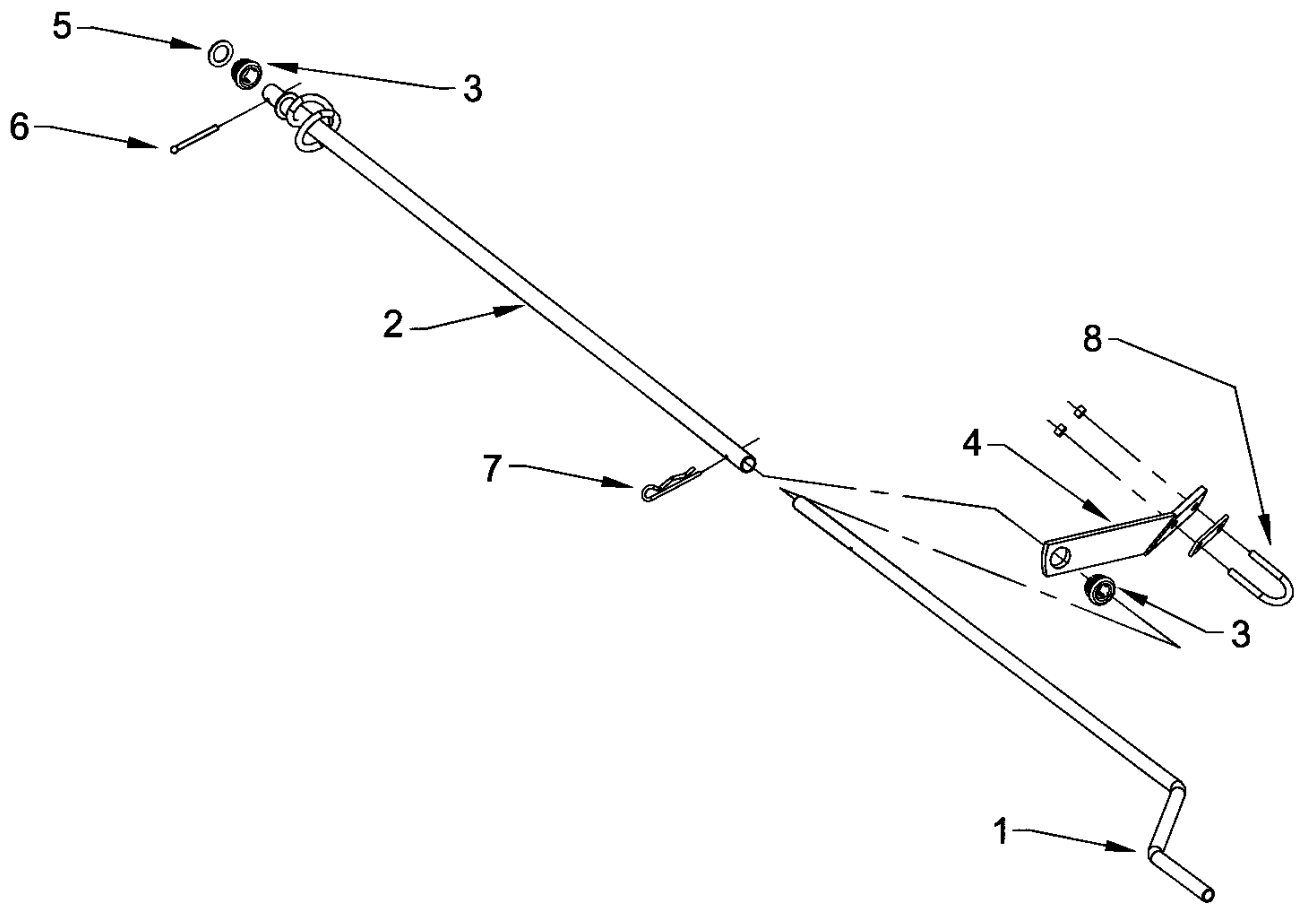

# PARTS





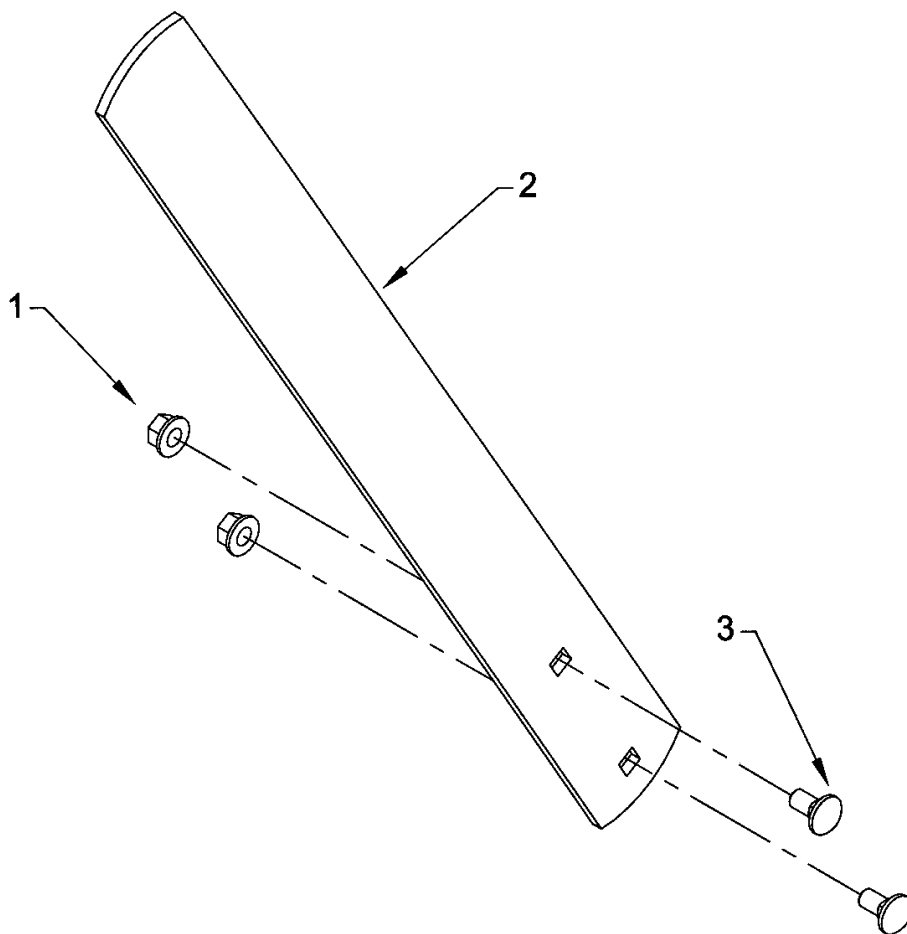

## Optional Drift Cutters - 8173

REF	DESCRIPTION	QTY	PART #
1	Flange nut 5/16" NC	4	O/L
2	Drift cutters	2	665746
3	Carriage bolt 5/16" NC x 5/8" Gr.5	4	O/L



O/L = Obtain Locally



# TORQUE SPECIFICATION TABLE

<b>GENERAL SPECIFICATION TABLE</b>													
<b>Use the following torques when special torques are not given</b>													
NOTE: These values apply to fasteners as received from supplier, dry, or when lubricated with normal engine oil. They do not apply if special graphited or moly sulphide greases or other extreme pressure lubricants are used. This applies to both UNF and UNC threads.													
<b>SEE Grade No.</b>		<b>2</b>				<b>5</b>				<b>8</b>			
<b>BOLT HEAD IDENTIFICATION MARKS AS PER GRADE</b> NOTE: MANUFACTURING MARKS WILL VARY.						  				  			
		Torque				Torque				Torque			
<b>BOLT SIZES</b>		<b>Pounds-Foot</b>		<b>Newtons-Meter</b>		<b>Pounds-Foot</b>		<b>Newtons-Meter</b>		<b>Pounds-Foot</b>		<b>Newtons-Meter</b>	
<b>Inches</b>	<b>Millimeters</b>	<b>MIN.</b>	<b>MAX.</b>	<b>MIN.</b>	<b>MAX.</b>	<b>MIN.</b>	<b>MAX.</b>	<b>MIN.</b>	<b>MAX.</b>	<b>MIN.</b>	<b>MAX.</b>	<b>MIN.</b>	<b>MAX.</b>
1/4	6.35	5	6	6.8	8.13	9	11.0	12.2	14.9	12	15	16.3	30.3
5/16	7.94	10	12	13.6	16.3	17	20.5	23.1	27.8	24	29	32.5	39.3
3/8	9.53	20	23	27.1	31.2	35	42.0	47.5	57.0	45	54	61.0	73.2
7/16	11.11	25	30	40.7	47.4	54	64.0	73.2	86.8	70	84	94.9	113.9
1/2	12.70	45	52	61.0	70.5	80	96.0	108.5	130.2	110	132	149.2	179.0
9/16	14.29	65	75	88.1	101.6	110	132.0	149.2	179.0	160	192	217.0	260.4
5/8	15.88	95	105	128.7	142.3	150	180	203.4	244.1	220	264	298.3	358.0
3/4	19.05	150	185	203.3	250.7	270	324	366.1	439.3	380	456	515.3	618.3
7/8	22.23	160	200	216.8	271.0	400	480	542.4	650.9	600	720	813.6	976.3
1	25.40	250	300	338.8	406.5	580	696	786.5	943.8	900	1080	1220.4	1464.5
1 1/8	25.58	-	-	-	-	800	880	1084.8	1193.3	1280	1440	1735.7	1952.6
1 1/4	31.75	-	-	-	-	1120	1240	1518.7	1681.4	1820	2000	2467.9	2712.0
1 3/8	34.93	-	-	-	-	1460	1680	1979.8	2278.1	2380	2720	3227.3	3688.3
1 1/2	38.10	-	-	-	-	1940	2200	2630.6	2983.2	3160	3560	4285.0	4827.4

## METRIC BOLT TORQUE SPECIFICATIONS

Size of screw	Grade No.	Pitch (mm)	Coarse thread				Fine Thread				
			Pounds-Foot		Newtons-Meter		Pitch (mm)	Pounds-Foot		Newtons-Meter	
			MIN.	MAX.	MIN.	MAX.		MIN.	MAX.	MIN.	MAX.
M6	4T 	1.0	3.6	5.8	4.9	7.9	-	-	-	-	
	7T 		5.8	9.4	7.9	12.7	-	-	-	-	
	8T 		7.2	10	9.8	13.6	-	-	-	-	
M8	4T	1.25	7.2	14	9.8	19.0	12	17	16.3	23.0	
	7T		17	22	23	29.8	19	27	25.7	36.6	
	8T		20	26	27.1	35.2	22	31	29.8	42	
M10	4T	1.5	20	25	27.1	33.9	20	29	27.1	39.3	
	7T		34	40	46.1	54.2	35	47	47.4	63.7	
	8T		38	46	51.5	62.3	40	52	54.2	70.5	
M12	4T	1.75	28	34	37.9	46.1	31	41	42	55.6	
	7T		51	59	69.1	79.9	56	68	75.9	92.1	
	8T		57	66	77.2	89.4	62	75	84	101.6	
M14	4T	2.0	49	56	66.4	75.9	52	64	70.5	86.7	
	7T		81	93	109.8	126	90	106	122	143.6	
	8T		96	109	130.1	147.7	107	124	145	168	
M16	4T	2.0	67	77	90.8	104.3	69	83	93.5	112.5	
	7T		116	130	157.2	176.2	120	138	162.6	187	
	8T		129	145	174.8	196.5	140	158	189.7	214.1	
M18	4T	2.0	88	100	119.2	136	100	117	136	158.5	
	7T		150	168	203.3	227.6	177	199	239.8	269.6	
	8T		175	194	237.1	262.9	202	231	273.7	313	
M20	4T	2.5	108	130	146.3	176.2	132	150	178.9	203.3	
	7T		186	205	252	277.8	206	242	279.1	327.9	
	8T		213	249	288.6	337.4	246	289	333.3	391.6	

# WARRANTY

---

The DR<sup>®</sup> SNOW THROWER is warranted for one (1) year against defects in materials or workmanship when put to ordinary and normal consumer use (ninety (90) days for any other use).

The Limited 1-Year Warranty on the DR<sup>®</sup> SNOW THROWER starts from the original ship date of the machine. The Limited 1-Year Warranty is applicable only to the original owner.

The owner is responsible for the performance of the required maintenance as defined by the manufacturer's owner's manual. The owner is responsible for replacement of wearable items such as shear bolts, skid shoes, cutting edge, bearings, chain, and belt, that are not covered under this warranty.

Country Home Products, Inc. certifies that the DR<sup>®</sup> SNOW THROWER is fit for ordinary purposes for which a product of this type is used. Country Home Products, Inc. however, limits the implied warranties of merchantability and fitness in duration to a period of one (1) year in consumer use, ninety (90) days in any other use.

*SOME STATES DO NOT ALLOW LIMITATIONS ON THE LENGTH OF IMPLIED WARRANTIES, SO THE ABOVE LIMITATIONS MAY NOT APPLY TO YOU.*

## FOR WARRANTY SERVICE

Contact Country Home Products, Inc., which reserves the right to examine the machine and make its own evaluation at its option.

## CUSTOMER SERVICE HOTLINE

Country Home Products, Inc.'s objective is to have 100% satisfied customers. For that reason, we operate a 7-day-a-week Customer Service Department for our Owners. You can access a Representative by dialing our **TOLL-FREE Hotline at 1(800)DR-OWNER (376-9637)**. The sole job of our well-trained and friendly folks is to ensure that you get any help you need in a timely fashion. They are there to answer all your questions including (1) inquiries on any of the above warranties, (2) inquiries about replacement parts, or (3) your questions regarding service, maintenance and operation.

**THIS WARRANTY GIVES YOU SPECIFIC LEGAL RIGHTS, AND YOU ALSO HAVE OTHER RIGHTS, WHICH VARY FROM STATE TO STATE.**

**COUNTRY HOME PRODUCTS<sup>®</sup>**

**Meigs Road, P.O. Box 25, Vergennes, Vermont 05491**

**TOLL-FREE 1(800)DR-OWNER(376-9637) • [www.dr-owner.com](http://www.dr-owner.com)**